

Front side of Apron

### Apron Instruction Sheet

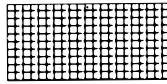

Pocket

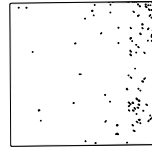

Wrong side of Apron

1. Take out one towel, a cut pocket piece of towel, and 2 ties from your packet.

2. Using the template place the triangles on the front upper right corner of your towel and draw a line. The longest point of the triangle is down. \* You will need to flip the triangle over to do the left side. Have your teacher check this before cutting!

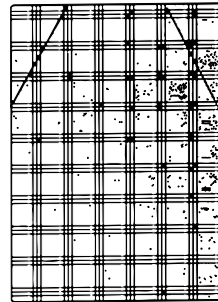

3. Cut straight along the chalk line.

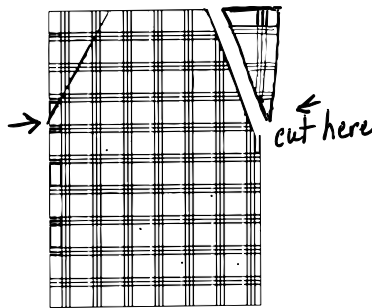

4. Serge the edges you just cut to keep them from fraying. Have your teacher check this.

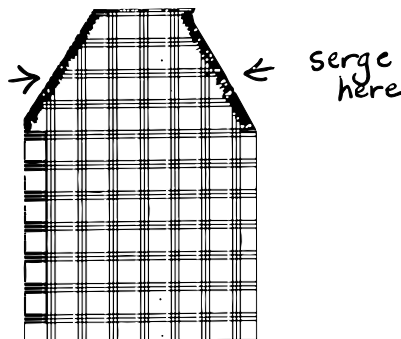

5. Fold the cut edges to the **wrong side**(inside) of the apron. Using a ruler gauge set on **1 + 1/4 inches**, pin the edges down with the **exact** measurement.

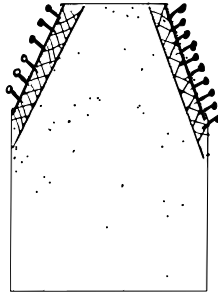

6. Set your machine to do a **straight stitch**. **3 length and 0 width**. Making sure to **backstitch** at the beginning and the end, Sew the folded-in piece next to the **inside** of the serging, starting at the top and ending at the bottom of the serging. This is a casing for your ties so do not sew the end openings shut!

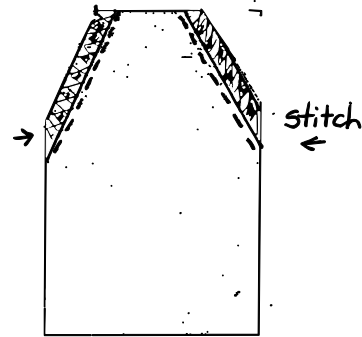

7. Take your cut pocket piece and serge the cut edge to keep it from fraying.

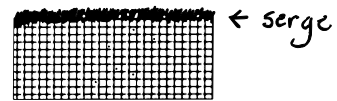

8. Lay the pocket piece onto the apron 6 squares (inches) from the bottom of your apron piece. Place the pieces right sides together. The serging will be up and **yes** the pocket will hang down lower than the apron. You will be flipping it up after it is sewn. **Pin**.

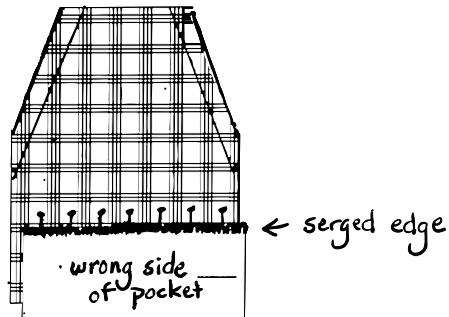

9. Once you have sewn along the serging line on the pocket flip it up and pin the sides down. Check to make sure the pocket is straight. Pin.

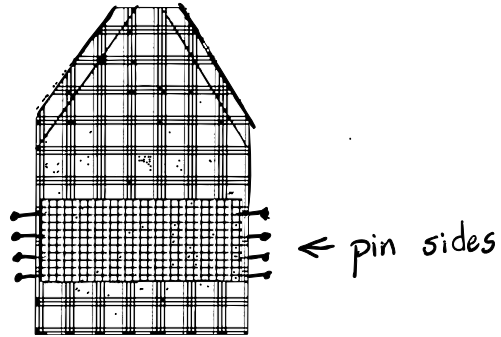

10. Now sew the sides of the apron keeping the presser foot even with the edge of the apron. Remember to Backstitch at beginning and end.

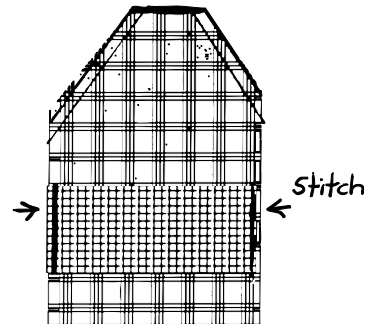

11. Measure in 6 inches from each side of the apron and draw vertical lines with a chalk pencil on your pocket. Your pocket now has 3 parts. If you would like to make 1 large and 2 little pockets or 4 little pockets, that is ok too. Just make sure the lines are straight. You are required to end up with at least 3 pockets.

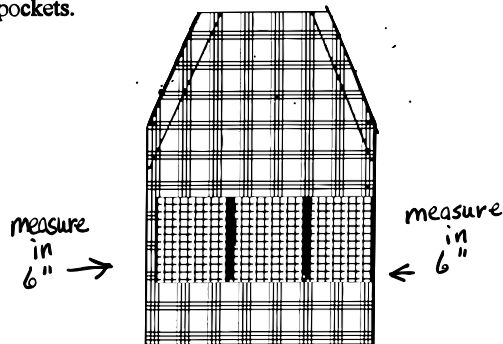

12. Now sew on the chalk lines to make your pockets, making sure you do not extend beyond the bottom or top of the pocket. Backstitch!

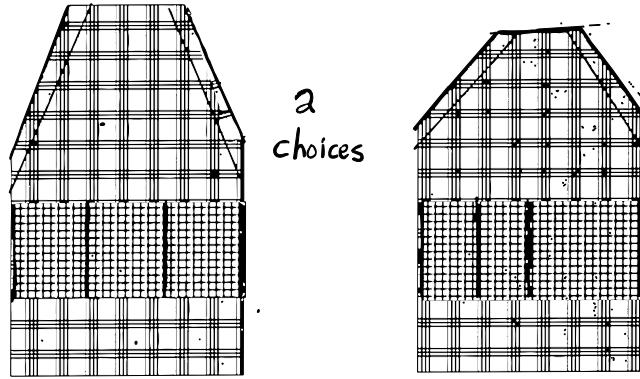

13. Take your two fabric ties and serge the short ends together.

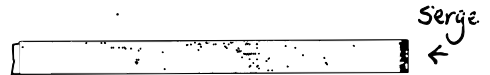

14. Fold the straps lengthwise with the serged end on the inside. Pin as you go. Do not fold both ties together. Open up your ties and they should be **very long**.

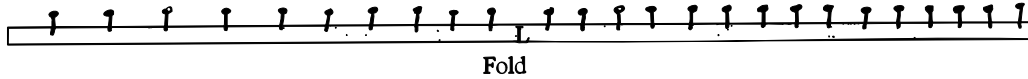

15. Serge the long edge of the ties together. Check as you go to make sure you are catching 2 layers of fabric.

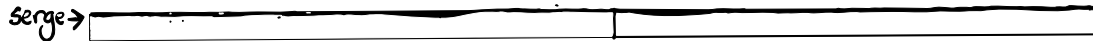

16. Insert the strap through one of the sides of the apron at the bottom, continuing to the top, down the other side of the top neck area and finishing by coming out at the bottom on the opposite side of the apron. Use a Safety pin to pull your straps through.

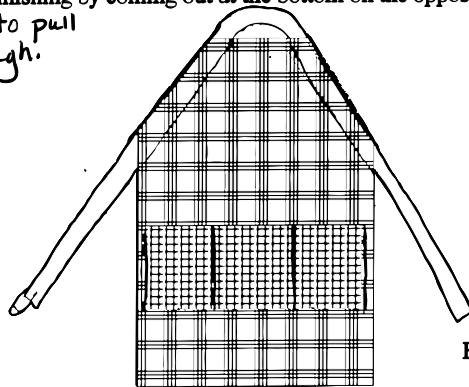

Enjoy your Apron!

